

920 Serie

TECHNICAL DESCRIPTION

Built on a one piece unit, all refrigeration and electrical connections between the condenser and evaporator are installed and tested in house. The unit is already filled with MP-66m MP-39, HP-62 or 134A refrigerant.

| | |
|-------------|------------------------------------|
| 920 M, L, | Over the road only |
| 920 ME, LE, | Over the road and electric standby |
| 920 M, ME, | Automatic air cycle defrost |
| 920 L, LE, | Automatic/manual hot gas defrost |

STANDARD EQUIPMENT

Compressor in Transit

Swash plate six cylinder, 9.3 cubic inches displacement vehicle engine mounted, belt driven.

Compressor electric standby

Swash plate six cylinder, 9.3 cubic inches displacement.

Standby Operation

Electric motor 2 H.P. single phase belt drive the compressor.

Fan Motors

Condenser 2 motors (2000 rpm) and evaporator 3 motors (2000 rpm) 12 volts D.C. totally enclosed permanent magnet motors.

Fan Blades

Condenser (2 blades 10") and evaporator (3 blades 10")

Defrost System

M - Air cycle defrost

L - Hot gas three system, initiated by a timer/limit control.

Protective Devices

High and low pressure control (commercial adjustable type), fused transformer/choke rectifier system, standby motor protected by a external manual reset. The transit system is protected by a circuit breaker.

Electrical

a) On the over the road the 12 volts D.C. is supplied by the vehicle battery system, NOTE: Vehicule must be equipped with a minimum 75 amperes electrical charging system.

b) On the standby, power is supplied by a 230 or 115 volts A.C. source with a minimum 20 amperes circuit/breaker. The 12 volts D.C. power is supplied by a transformer/choke rectifier system.

Electric load

In transit: 18 amps D.C.

Standby : 18 amps 115 volts A.C. 1.5 HP.

12 amps 230 volts A.C. 2. HP.

OPTIONAL EQUIPMENT

- Electric heat N/C
- Standby Motor (3 phase) N/C
- 2 pieces unit N/C
- Water heating from the engine
- Thermometer

WARRANTY

Thermo Plus offer a one year warranty, parts and labor, on all refrigeration units.

WEIGHT

| | |
|------------|------------------|
| 920 M,L | 325 pds (148 kg) |
| 920 ME, LE | 425 pds (190 kg) |

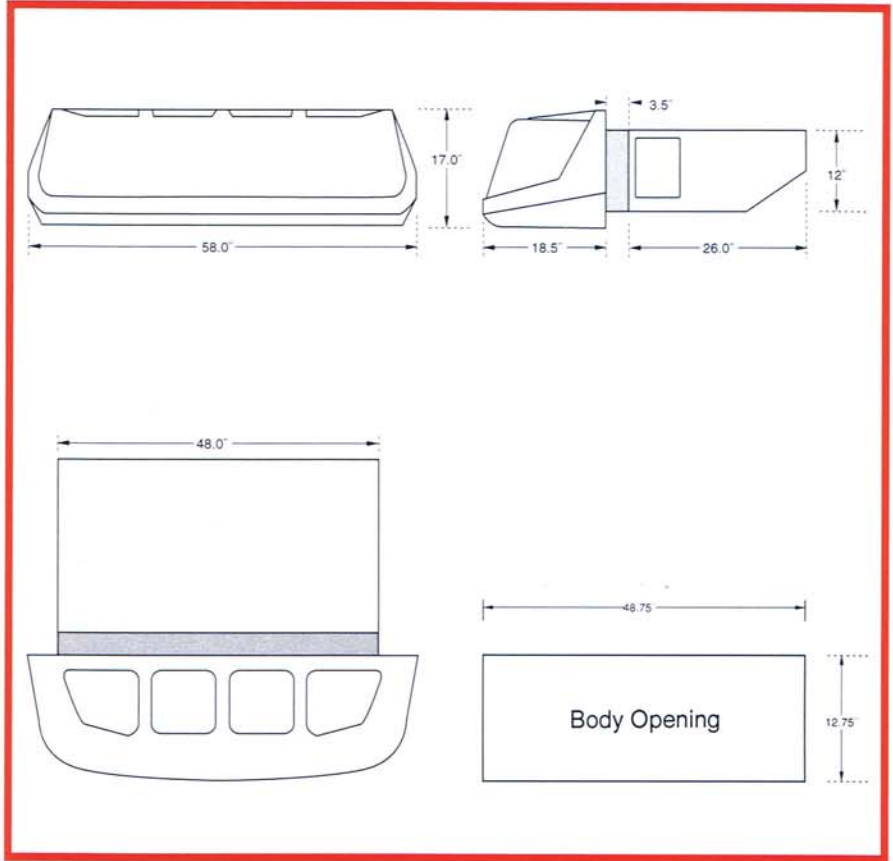

SPECIFICATIONS SUBJECT TO CHANGE WITHOUT NOTICE.
Cooling temperature/Capacity ambient 100°F (37.8°C)

| EVAPORATOR Return Air Temp. | BTU/H (kCAL/H) | |
|--------------------------------|-----------------|------------------|
| | Engine/2400 rpm | Standby/1800 rpm |
| 0°F (-17.8°C) | 8,000 (2017) | 7,000 (1764) |
| 35°F (1.7°C) | 16,000 (4035) | 14,000 (3528) |

